

## 1. Introduction

Today’s national and international regulations laws require that data is archived and reproducible for several years. Software developers spend major time in order to guarantee the needs of lawyers and data security engineers. Database technology as the core technology for data storage of applications can support the developers in order to master the task of reproducible data engineering.

MySQL, as the leading open source database management system, offers the possibility of extending its core functionality of storage management with a pluggable interface. Many storage engines offer different behavior for the

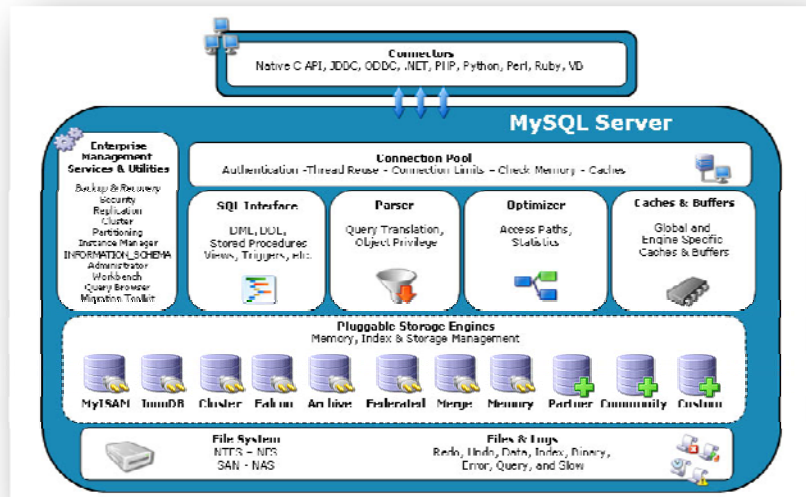

MySQL pluggable storage engine architecture from [www.mysql.com](http://www.mysql.com)

various needs of the Application. MyIsam for example offers fast storage access but does not deliver the complete ACID<sup>1</sup> properties InnoDB or Falcon offer. The Archive storage engine also offers a very low disc footprint and fast inserts for log data. To leverage this technology and offer support for data versioning the DDEngine Group has created a middleware between the common MySQL server and its storage engines. This middleware operates as a versioning engine and ensures that all changes on selected tables are versioned. The Revision engine is not a new storage type but uses the available storage engines to create the data versioning. Retrieval of the data is controlled by specific session variables. This way it is possible to have parallel transactions on historic and current data.

## 2. Versioning Modes

Currently the Revision engine supports two different versioning modes. Single table and Multi table. With single table versioning the current table data is kept with the most current data in exactly one table. This mode is efficient for frequent update statements since the new data is simply inserted into the table in parallel with the historical data. This method slows down select statements since more table data needs to be scanned.

The two table option stores the currently active data row in a table separate from the historical data sets. Update statements loose performance on this mode

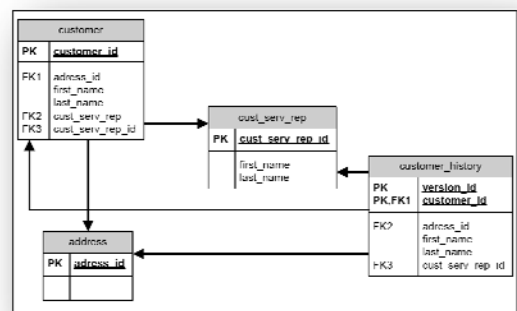

Example for multi table versioning as created by the Revision engine

<sup>1</sup> Atomicity Consistency Isolation Durability

since old data is removed from the current table and inserted into a versioning table. This requires an Update statement on the table in order to retrieve the complete most current row and an Insert statement into the history table. Select statements are not slowed down in comparison to a conventional table without versioning.

Future versions will include another option - the tri table. This mode targets applications that manly change only a very limited number of columns. If tables are very wide the versioning of the whole row may be very costly since the whole row is copied to a different internal table. This third mode will create an internal table versioning the data per column. There is then no need to version the whole row but only the changes on the column. This reduces the disk footprint of the versioning tables if the row size extends a specific limit. Also the speed of the update statements may benefit from this constellation.

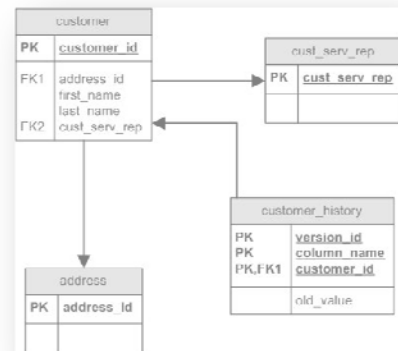

Tables for column based versioning

### 3. Installation

#### Linux – Binary Distribution

1. Download the binary distribution from <http://www.ddengine.org> appropriate for your MySQL system. If you do not have MySQL installed please follow the instructions at <http://www.mysql.com>.
2. Unpack the zip file to a temporary location (<temp>)
3. Copy the .so file, located in <temp>/dist folder, to the plug-in directory of your MySQL Server
4. Open a connection to the MySQL server with admin rights
5. Issue the following statement on the SQL command line:  
***INSTALL PLUGIN revision\_engine SONAME 'revisionengine.so'***
6. To check if the plug-in was installed properly issue the following command on the MySQL command line:

#### Windows

Currently MySQL does not support a runtime plug-in for Windows. The available distribution for windows is a completely compiled MySQL system that can be downloaded from [www.mysql.com](http://www.mysql.com).

1. Download and install the standard MySQL windows server downloadable from [www.mysql.com](http://www.mysql.com)
2. Unpack the zip file to a temporary location (<temp>)
3. Overwrite the MySQL .exe file in the install directory of your installed MySQL server with the MySQL.exe file located in <temp>
4. To check if the plug-in was installed properly issue the following command on the MySQL command line:

